

Computational and Experimental study of damage and failure in carbon/glass fiber-reinforced composite materials (‘Early Career Research Award’, No : ECR/2018/001638)



Funding Agency- SERB

Dr. Nelson Muthu (PI), Department of Mechanical Engineering, Indian Institute of Technology Guwahati, Assam 781039

Theme:- Composite Materials; **Objectives:-** (i) Manufacture glass fiber reinforced plastics (GFRP) and carbon fiber reinforced plastics (CFRP) test coupons at the lab scale, (ii) Subject the test coupons to fracture and damage experiments using tensile and drop weight test (iii) Develop a robust numerical model that will predict damage behavior in GFRP/CFRP and demonstrate its reliability by validating against the experiments (iv) Improve the manufacturing process to further reduce the void content and increase the fiber volume fraction by heat treatment and varying other manufacturing process parameters, (v) Contribute to the development of composite manufacturing facility at IIT Guwahati.

Research Output

- ❖ Developed composite manufacturing lab at IIT Guwahati in the department of mechanical engineering.
- ❖ Develop composite (double cantilever beam - DCB) specimens with controlled crack for fracture mechanics experiments. The crack was generated using the Teflon sheets. The DCB specimens were subjected to tensile tests in the UTM and the force vs. displacement curves for the specimens were recorded.
- ❖ Students and project staff were given training on the NDT using ultrasonic scanner machine to identify damage in the composite specimens.

International Journals:

- ❖ P. Dinesh, P. G. Ranjith, M. R. Behera, N. Muthu “Experimental and numerical (EFG method) studies on sedimentary rock under varied salinity conditions” International Journal of Rock Mechanics and Mining Sciences, 104909; 148: 2021.
- ❖ P. Rakesh, A. more, M. Kumar, N. Muthu “Probabilistic failure prediction in a double composite cantilever beam with single and double source uncertainty” Composite Structures, 114870; 379: 2021.

International Conferences:

- ❖ A. Kumar, N. Muthu, R. G. Narayanan “Equivalent In-plane Elastic Properties of Periodic Re-entrant Honeycombs – Strain-energy approach and FE modelling” International Conference on Experimental and Computational Methods in Manufacturing (ICECMM 2021), NERIST, Aug, 28-29, 2021.
- ❖ Manash Baishya, Bikram Sahariah, Nelson Muthu, Prasenjit Khanikar “High-stiffness metamaterial composite structure with plate reinforced strut-microlattice” 2022 TMS Annual Meeting & Exhibition, 27 Feb – 3 March, Anaheim, California, USA (Accepted).

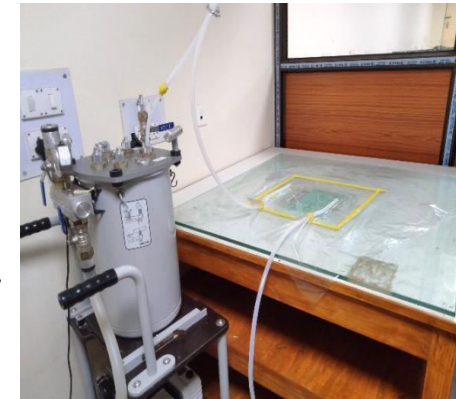

Composite Manufacturing Lab



Interface Crack Studies

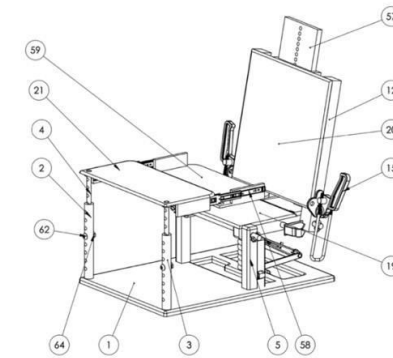

A Versatile standing cum sitting device with composite materials

PATENT FILED

Yengala Sasibhushan,
Nelson Muthu “A Versatile Standing Cum Sitting Device For Rehabilitation And Standing Aid For Paraleptic Patients” (DoA: 25-06-2021, App No.: 202131028647).